

Vintage Truck

20

This 1930s' vintage truck is one of my favorite display pieces. It was made from a piece of cherry that I found on a side road in Maine near an old abandoned sawmill. The walnut wheels enhance the natural warmth and charm of the piece. To make a truck for active play, I'd substitute maple or birch for the cherry (see the gallery photo on p. 47). This toy is one of the most challenging to build in the book, so to make the job easier I've separated the process into four different subassemblies: cab, front end, rolling chassis and bed.

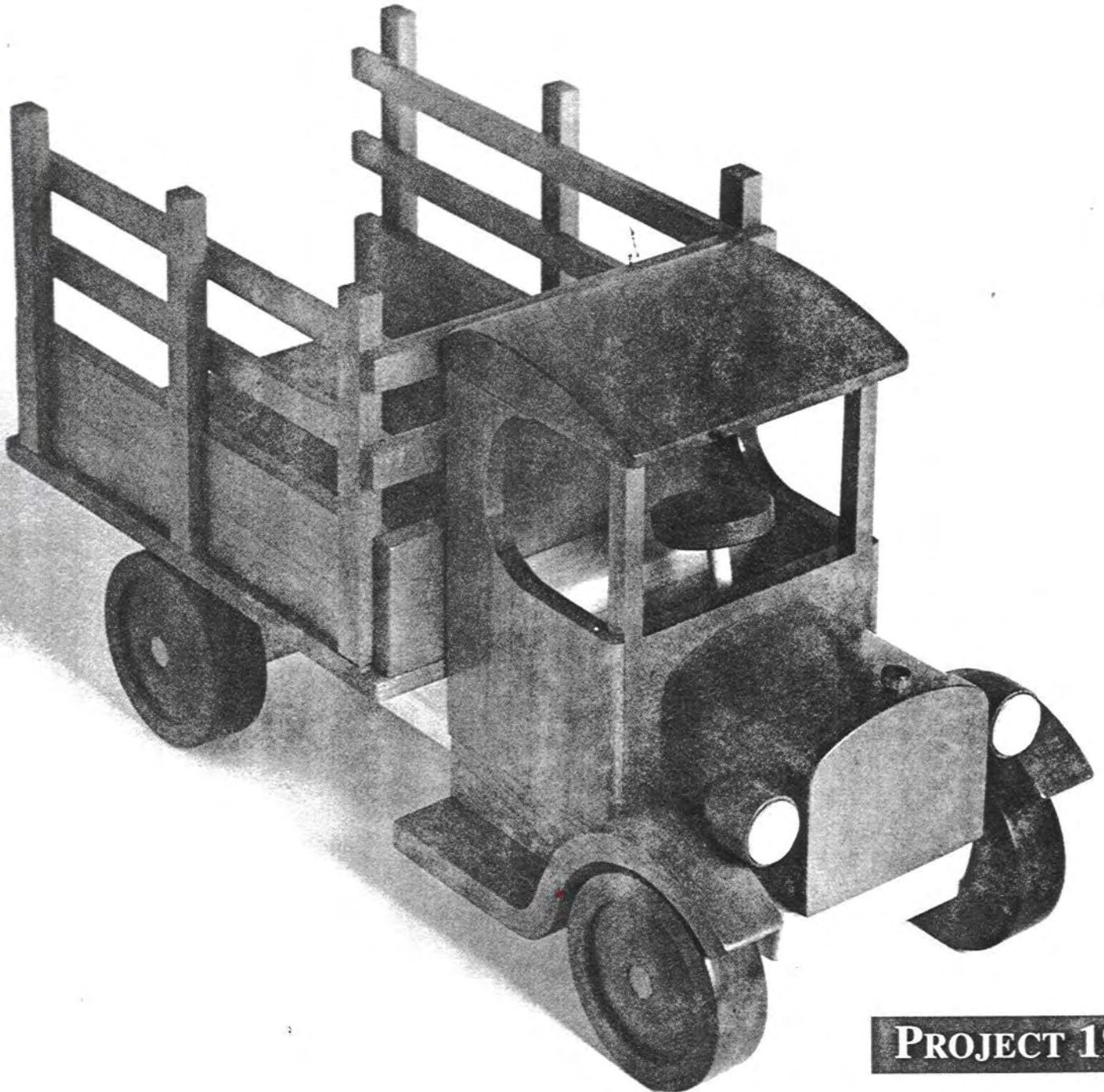

PROJECT 19

Parts Preparation

CAB

1. Cut the door-panel blanks to size. Fasten the panels together with double-sided tape (with the best sides together). Rabbet both sides and the bottoms, and cut out the window using the full-size pattern on p. 125.

2. Cut the back wall and windshield to size, and then make the window cutout in the windshield.

3. Cut the cab floor to size.

4. Drill an angled hole (10°) for the steering column in the steering-column support while the support is still in block form (see p. 10). Then secure the support to an auxiliary block to make the 45° cut on the bandsaw.

5. Use the full-size pattern on p. 125 to lay out the roof profile, bandsaw the curve in the top surface and then sand smooth (see p. 84).

6. Shape the seat blank using the full-size pattern on p. 125. Make the angle cut last.

7. Cut the steering wheel with a hole saw.

8. Cut the steering column to length.

FRONT END

1. Cut and shape the hood, and then drill a 3/16-in.-dia. hole in each side for mounting the headlights.

To make the headlights, use a brad-point bit to drill a 1/2-in.-dia. recess about 1/16 in. deep in the end of two cherry dowels (see the photo below). Turn the back end round.

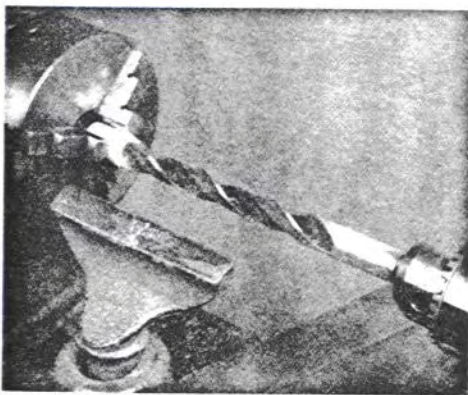

End-drill a cherry dowel to make the recessed hole for the headlight button.

3. Cut and shape the radiator, and then drill the top for the radiator cap, which is turned from a 1/4-in.-dia. walnut dowel.

Lay out and cut the fenders and fender supports. Because of the short grain just above the running board, the fenders will be fragile; I glue the fender supports to the fenders at this time to add structural strength and minimize the risk of breakage.

Parts List

Quantity	Description	Finished Dimensions	Material
2	Door panels	1/4 x 2 5/16 x 3 9/16	Cherry
1	Back wall	1/4 x 2 7/8 x 3 9/16	Cherry
1	Windshield	1/4 x 2 7/8 x 3 9/16	Cherry
1	Cab floor	1/4 x 1 13/16 x 2 7/8	Cherry
1	Roof	1/2 x 3 3/16 x 2 1/2	Cherry
1	Seat	1 3/16 x 1 1/4 x 2 9/16	Birch
1	Steering-column support	1 1/16 x 1 1/16 x 2 9/16	Cherry
1	Steering column	3/16-in.-dia. dowel by 2 1/4 in. long	Birch
1	Steering wheel	1 in. dia. by 1/4 in. thick	Cherry
1	Hood	1 5/8 x 2 x 1 11/16	Cherry
1	Radiator	1/4 x 2 1/8 x 1 11/16	Cherry
1	Radiator cap	1/4-in.-dia. dowel by 5/8 in. long	Walnut
2	Fenders	1 7/16 x 1 11/16 x 4 1/2	Cherry
2	Fender supports	3/16 x 1 5/16 x 2 1/2	Cherry
2	Headlights	3/8-in.-dia. dowel by 3/4 in. long	Cherry
2	Headlight brackets	3/8-in.-dia. dowel by 5/8 in. long	Birch
2	Headlight lens	1/2-in.-dia. studded pearl buttons	Plastic
1	Main chassis	9/16 x 2 1/4 x 9 3/16	Maple
1	Bed chassis	9/16 x 2 3/4 x 5 3/4	Maple
2	Axle housings	5/8 x 3/4 x 2 3/4	Birch
2	Axles	5/16 in. dia. by 4 1/2 in. long	Birch
4	Spacer washers	3/16 in.	Steel
4	Wheels	1 7/8 in. dia. by 3/8 in. thick	Walnut
1	Floor panel	1/4 x 6 x 4 5/8	Cherry
6	Posts	1/4 x 5/16 x 3 1/2	Cherry
2	Side walls	1/4 x 1 1/4 x 5 13/16	Cherry
4	Side rails	3/16 x 5/16 x 5 13/16	Cherry
1	Front wall	1/4 x 1 1/4 x 4 5/8	Cherry
2	Front rails	1/4 x 5/16 x 4 5/8	Cherry

ROLLING CHASSIS

1. Cut the main chassis to size. Bevel the front (5°) and back (10°) ends and cut a 5/8-in.-wide by 1/4-in.-deep dado in the bottom for the axle housings.

2. Cut the bed chassis to size, beveling just the back edge at 10°. Glue the bed chassis to the main chassis, centered left to right and with the rear bevels aligned.

3. Cut and drill the axle housing (see p. 12).

4. Cut the wheels with a hole saw, and true them up on the lathe (see p. 13).

5. Cut the axles to rough length, and trim to final length after dry assembly.

BED

1. Cut the floor panel to size, and then r... 1/4-in. by 1/16-in. dado along each side (1/8 in.

from the edge) for the side panels. Cut a 1/4-in. by 1/16-in. rabbet in the front edge for the front wall.

2. Cut the side walls and front wall to size. Cut a 3/8-in. by 1/16-in. rabbet in each end of the front wall.

3. The vertical posts are rabbeted on their lower ends to fit over the side walls and notched in the middle and at the top for the side rails. Make the cuts using the technique described in the sidebar on the facing page.

4. Rip the side and front rails to size. Make a rabbet cut on each end of the front rails.

If this truck is destined for the playground rather than the display shelf, I'd forego the fancy (and fragile) post-and-rail bed, and substitute some lower, solid-panel sides (as shown in the gallery photo on p. 47).

Assembly

Finish all parts as described on pp. 16-18. Note that this toy is pre-assembled in four sections before final assembly.

CAB

1. Glue the cab floor and door panels to the back wall, and then glue the windshield to the door panels. The front corners of the cab may have to be notched to clear the fenders; this should be determined during dry assembly.
2. Glue the steering-column support to the floor and the seat to the back wall. Glue the steering wheel to the steering column, and then glue the lower end of the steering column into the hole in the steering-column support.
3. Glue on the roof.

FRONT END

The fenders and fender supports were glued together before sanding and finishing.

1. Glue the radiator to the front of the hood and the radiator cap into the radiator.
2. Epoxy the pearl buttons and the headlight brackets into the headlights.
3. Epoxy the headlight brackets into the holes in the sides of the hood.

ROLLING CHASSIS

1. Glue the axle housings into the chassis dados.
2. Insert the axles into the housings, add washers and glue on the wheels.

BED

1. Because the glue areas on the bed parts are so small, I use epoxy for all glue joints here. Glue the front and side walls to the floor panel, and the posts to the side walls. Glue the front and side rails to the posts.

ASSEMBLING THE COMPONENTS

1. Glue the assembled bed onto the bed chassis, centered left to right and with front edges aligned.
2. Glue the cab onto the main chassis, centered from left to right and flush against the front end of the bed.
3. Glue the hood assembly onto the main chassis, centered and butted against the cab.
4. Glue the fenders and fender supports onto the main chassis, with the back edge of the support aligned with the back edge of the cab. Some minor shaping on the fenders may be necessary to clear the headlights. Once the fenders are fitted, add some epoxy glue between the headlight and fender for additional support.

Making Posts

The bed for the vintage truck includes posts that are rabbeted and notched to receive the side rails and side walls. Machining parts this small is dangerous, so I cut the rabbet and the dados

in a larger block, as shown in the drawing, and then rip the individual posts from this block. Use the spacer-block technique to cut six identical, 1/4-in.-wide posts, as shown in the photo below.

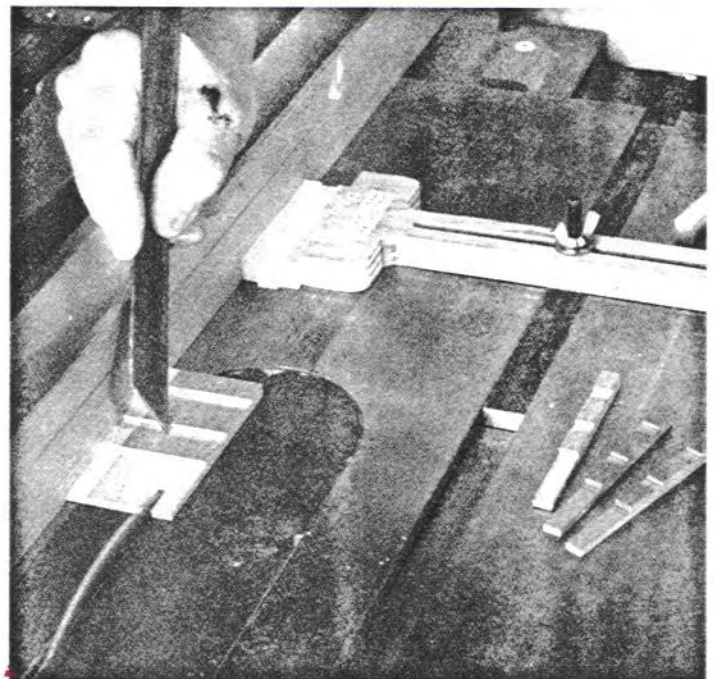
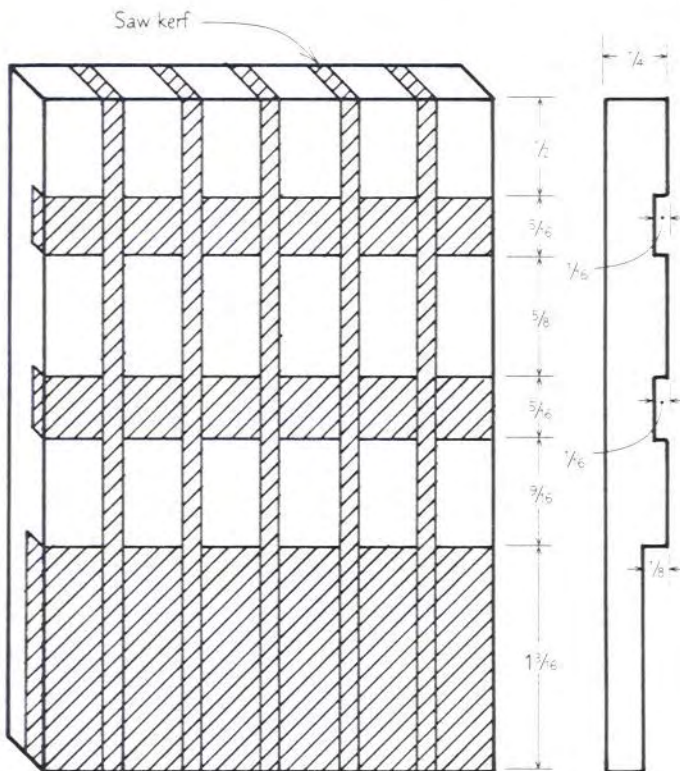

Rip posts for the bed from a precut board. Use spacer blocks to set the rip fence, removing one spacer for each cut.

Vintage Truck

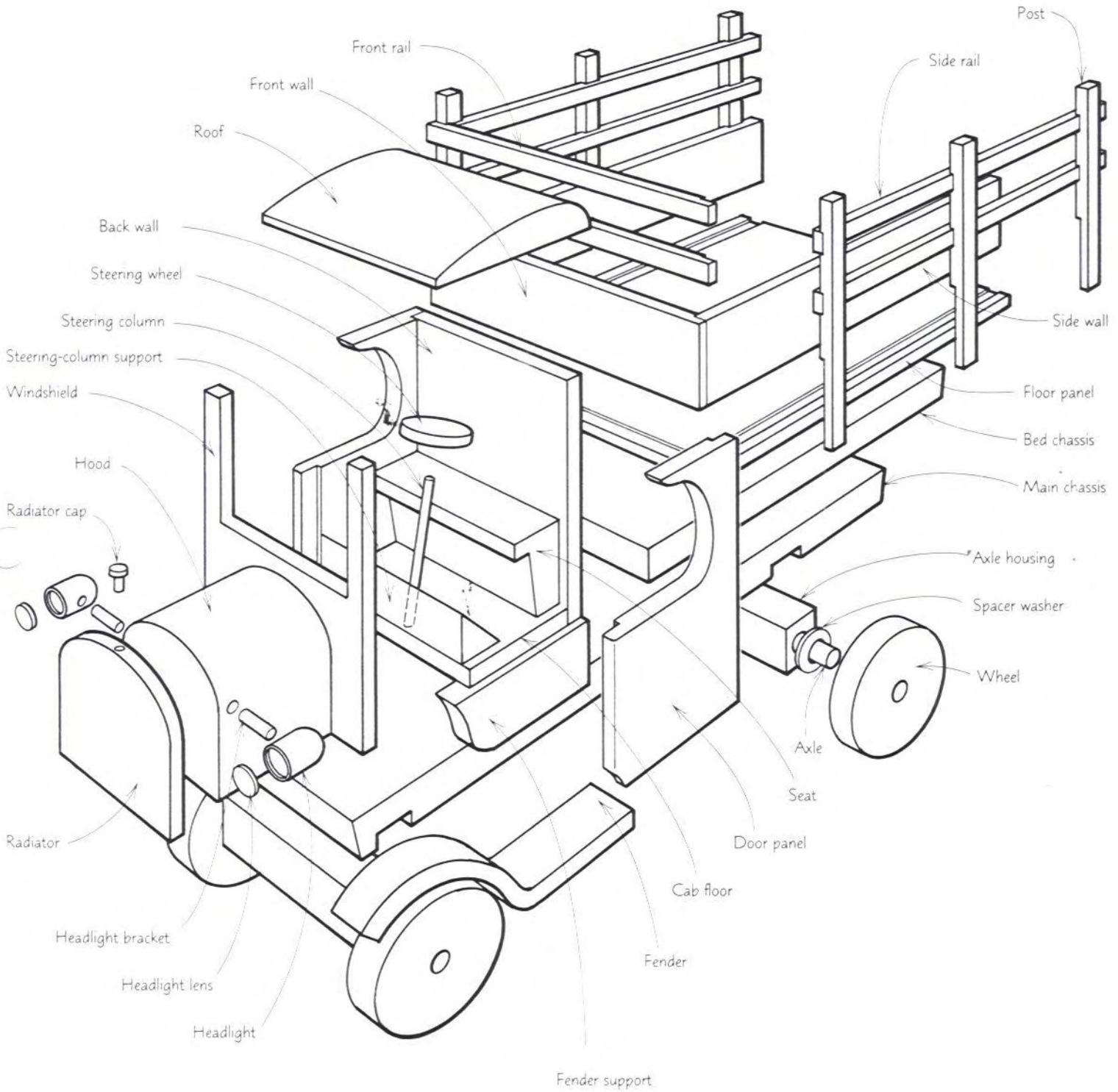

FRONT VIEW

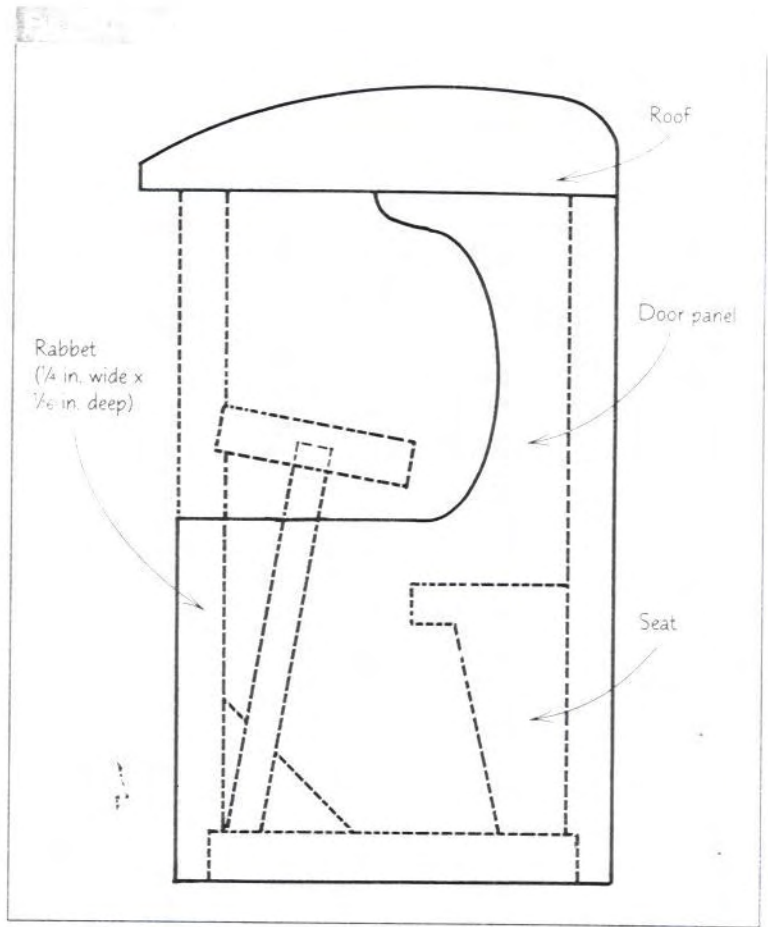
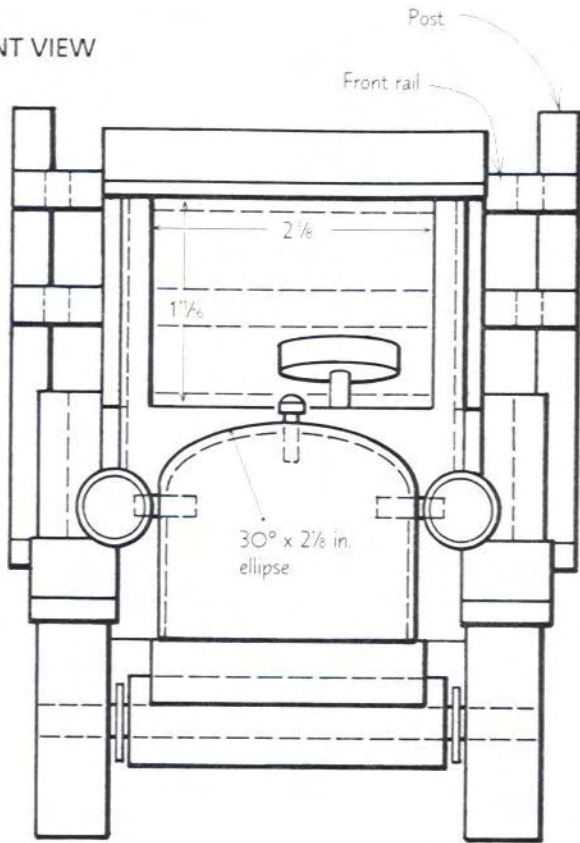

Cab section

SIDE VIEW

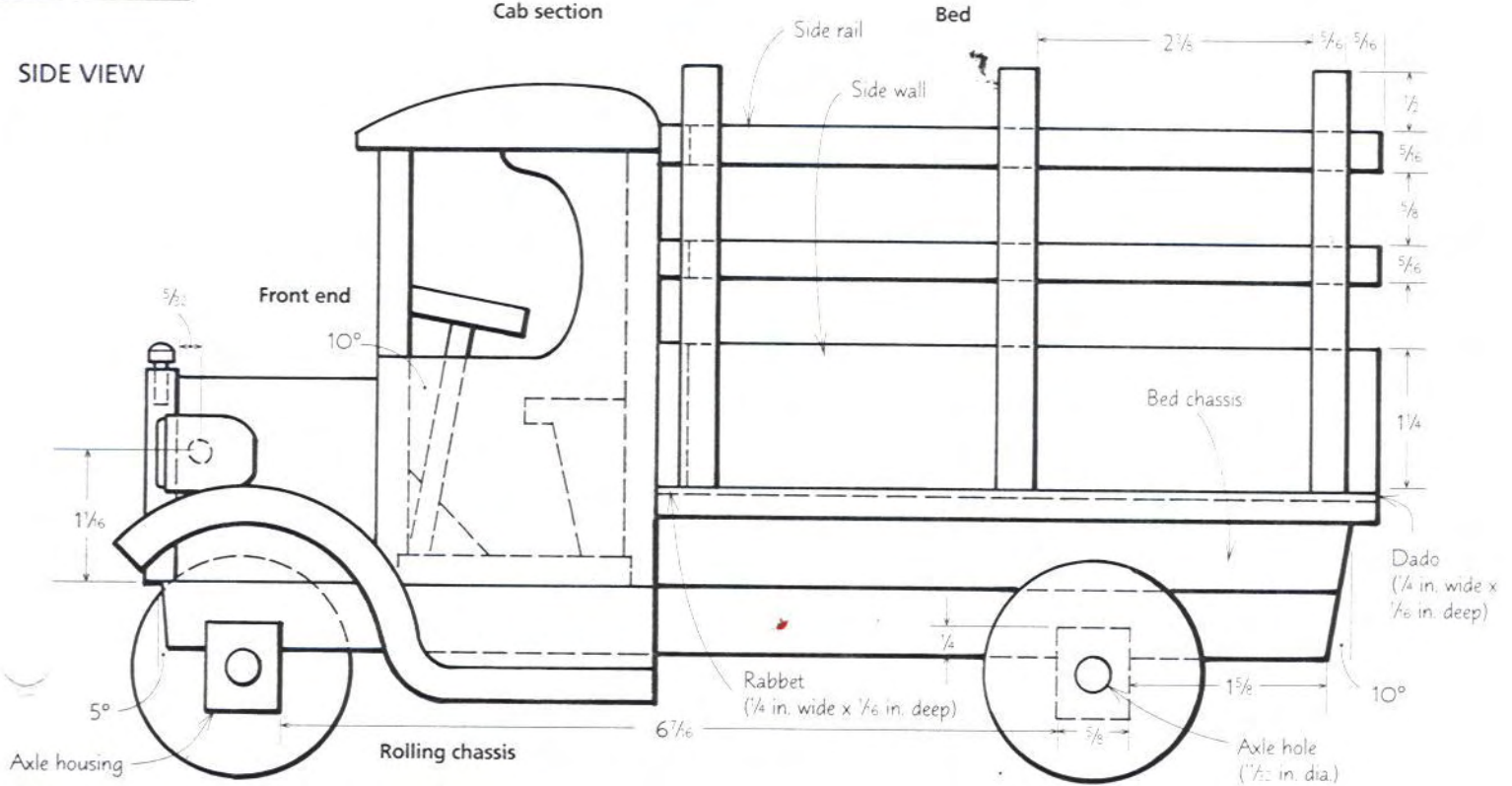

Scale 65%
Enlarge 157%